



User Manual of Storage Lithium Battery (Certificate Model: YNBB16S100KX-L)

Manual Instruction

This user manual is the instructions for using 2U wall-mounted battery modules. Please read this manual carefully before installing the battery, and follow the instructions during the installation. For any confusion, please contact the manufacturer immediately for advice and clarification.

CONTENTS

1. Safety Disclaimer	1
2. Product Introduction	1
3. Specification	4
4. Interface	5
5. Battery Module Safety Processing Guide	10
6. Installation	11
7. Safety precautions	16
8. Abnormal Conditions and Fault Handling	17
9. Emergency	18
Legal statement	18

1. Safety Disclaimer

Users must read this user manual carefully and operate it according to the safety precautions required by this user manual before installing, using and repairing the battery. Our company will be responsible for nothing if it happens to any injuries and loses caused by improper operations.

Attention
It may cause moderate injury or minor injury to human beings, or even damages to product because of the danger caused by failure to operate as requirements.
Danger
It may cause fire or serious personal injury, or even death because of the danger caused by failure to operate as requirements.

2. Product Introduction

AMENSOLAR AW5120, a 2U wall-mounted battery module, is one of the new energy storage products that can be used to support reliable power for a variety of equipment and systems. The product is especially suitable for the application scenarios of high power, limited installation space, limited bearing capacity and long cycle life. The battery module has a built-in BMS battery management system that can manage and monitor battery information, including voltage, current, and temperature. In addition, BMS can also balance the charge and discharge of the battery to extend the cycle life. Multiple batteries can be connected in parallel to expand capacity and power in parallel to achieve the requirements of greater capacity and longer power support time.

2.1 Product features

- Lithium iron phosphate battery, the weight is reduced by 40% compared with the same specifications of lead-acid battery;
- Wall-hanging structure, the pack can be mounted on the wall with the characteristics of easy maintenance, flexibility and versatility;
- Battery pack shell with insulation coating metal sheet metal;
- The power output and input terminal of the battery pack adopts a high-power quick-plug connector, which supports hot swap.
- The battery pack can be used in parallel with a maximum of 16 pieces and cannot be used in series.
- Low self-discharge, no memory effect, shallow charge and shallow discharge performance is better;

2.2 Function introduction

- ✓ ARM low power processor;
- ✓ Professional battery management chip;
- ✓ Support active and passive charging current limiting mode (maximum 20A);
- ✓ Supports CAN / RS485 communication;

- ✓ Built-in 4-channel temperature acquisition;
- ✓ Support high and low temperature over-charge and over-discharge protection;
- ✓ Support the battery balancing function;
- ✓ Support for SOC calculation and calibration;
- ✓ Support for two-level over-current protection;
- ✓ Support the output short-circuit protection;
- ✓ Support for polar reverse-connection protection;
- ✓ Support for data storage;
- ✓ Multiple automatic fault detection (sampling, MOS, battery failure).

2.3 Product Size



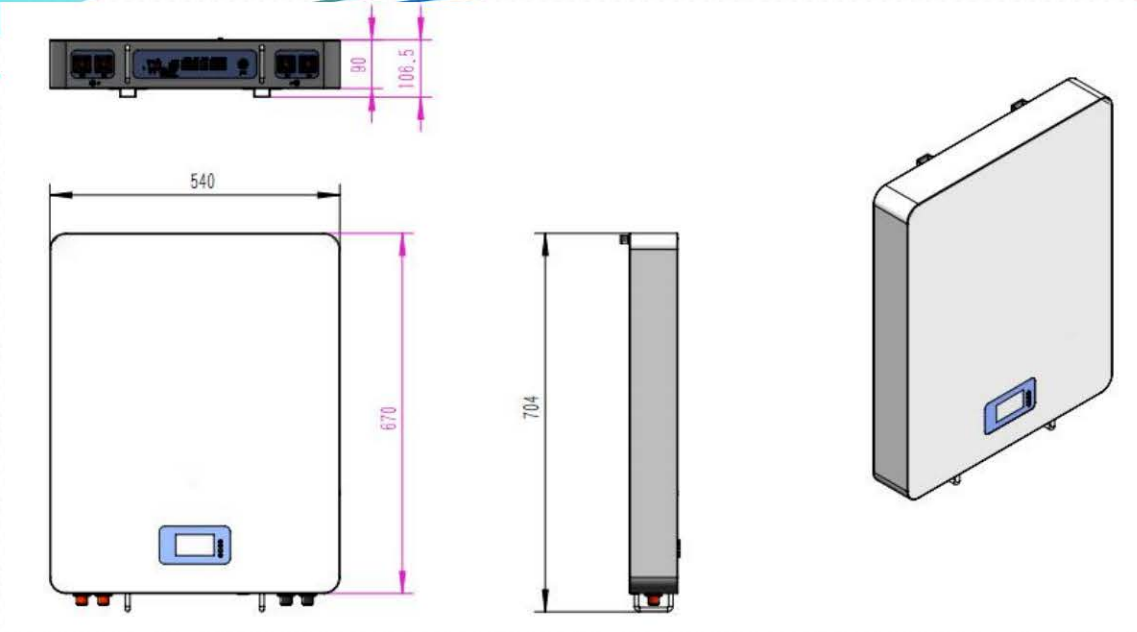

Battery Module Size

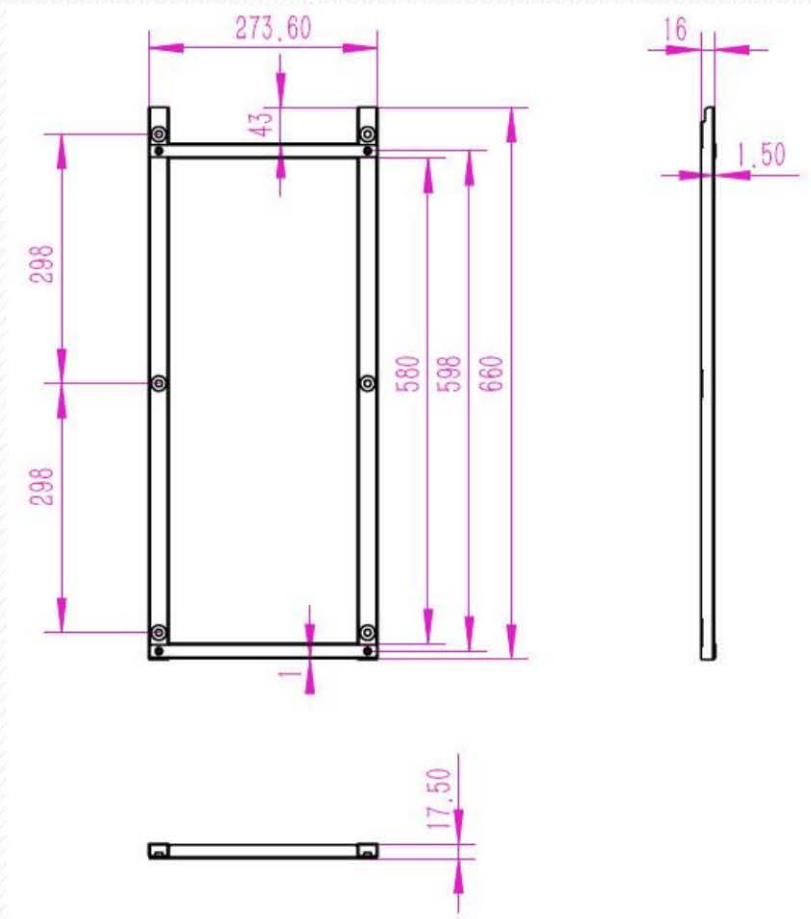

Installation Bracket Size

3. Specification

ITEM	AW5120
Certificate Model	YNBB16S100KX-L
Battery Type	LiFePo4
Mount Type	Wall Mounted
Rated Voltage (V)	51.2
Operating Voltage Range (V)	44.8~57.6
Floating Charge Voltage (V)	55±1
Capacity (Ah)	100
Energy (KWh)	5.12
Internal Resistance	≤50mΩ
Max Charge Current (A)	100
Rated Charge Current (A)	50
Max Discharge Current (A)	100
Rated Discharge Current (A)	50
Charging Temperature	0°C~+56°C
Discharging Temperature	-20°C~+56°C
Recommended Working Temperature	+10°C~+30°C
Storage Temperature	0-25°C / 12 months
Relative Humidity	5% - 95%
Dimension (L*W*H mm)	Module: 540*704*90
Weight (KG)	45±0.5
Communication	External: CAN / RS485 Internal: RS485 PC upper computer computer: RS232
Enclosure Protection Rating	IP21
Cooling Type	Natural Cooling
Display Mode	Indicator Light / Screen
Cycles Life	≥6000
Recommend DOD	90%
Design Life	20+ Years (25°C@77°F)
Safety Standard	UL1973/CE/IEC62619/UN38.3
Max Number of Parallel	16

4. Interface

4.1 Interface definition

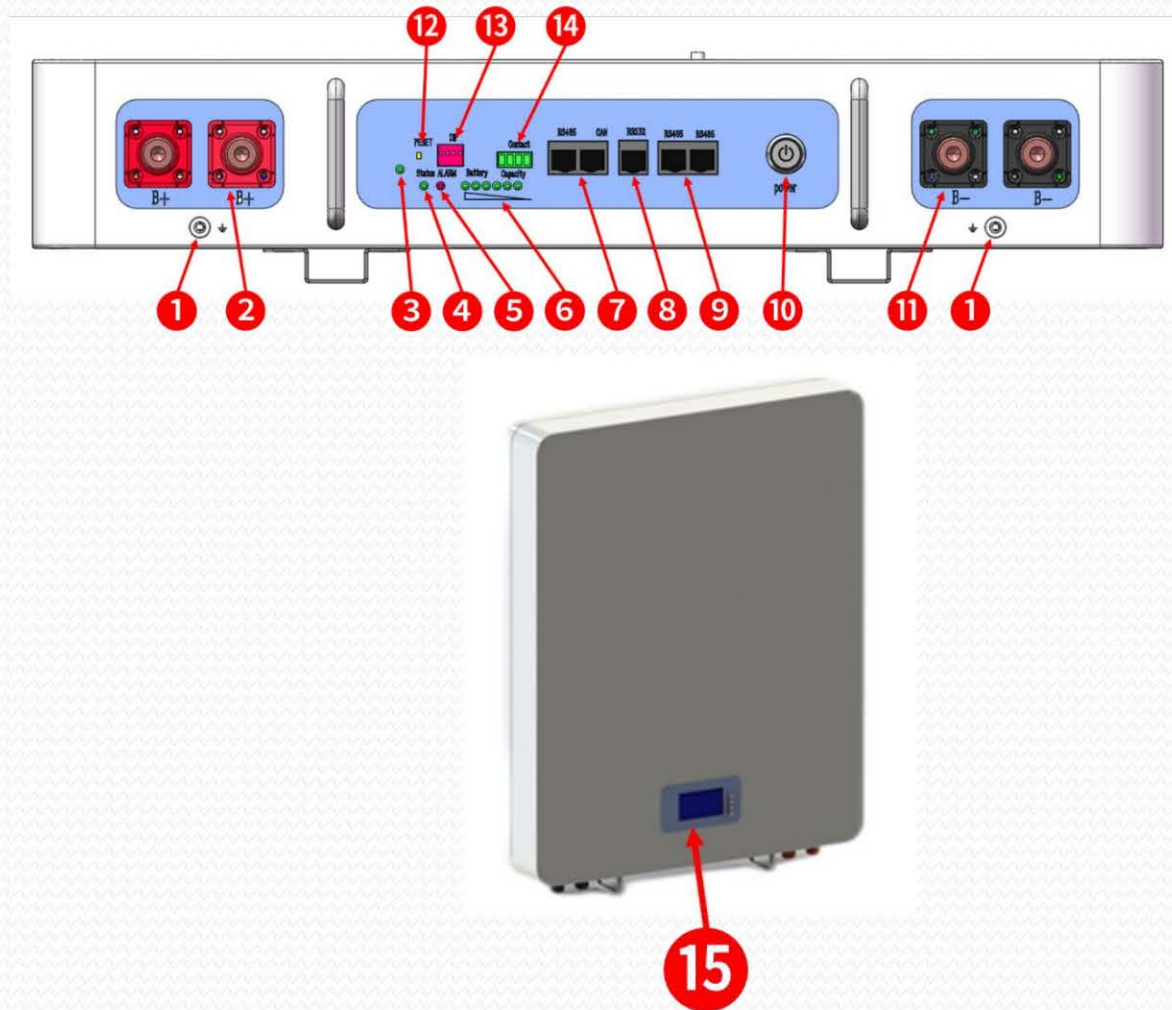

❶	Ground wire hole	❹	RS485 Interface
❷	Positive Terminal	❺	Power on/off
❸	Power Indicator	❻	Negative Terminal
❹	Status Indicator	❼	Reset
❺	Alarm Indicator	❽	Dip Switch Address
❻	Battery Energy Indicator	❾	Dry Contact
❼	RS485 / CAN Interface	❿	BMS Screen
❽	RS232 Interface		

Power Indicator

Always on after power on, and off after power is turned off.

Ground wire hole

Battery module grounding.

Status Indicator

Showing the power is on, the BMS is on / off

Alarm Indicator

Battery fault indicator light, red indicates fault, green indicates normal.

Battery Energy Indicator

Displaying the energy of battery, six indicators show the current power supply.

BMS Screen

The parameter of the battery will be shown on the screen.

1) Main Menu page

After turning on/activation, the welcome interface will be displayed, and press the menu key to enter the main menu page:

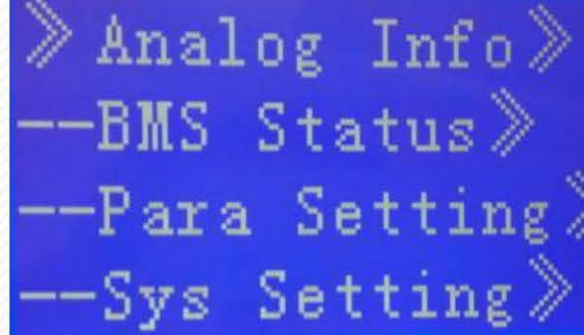
Welcome Interface	Main Menu
	

2) Battery parameter collection page

When the cursor "»" refers to the "battery parameter collection", press Enter key will enter the "battery parameter collection" page, as shown in the figure below:

3) Description of keys

(1) SW1----MENU, SW2----ENTER, SW4----DOWN, SW5----ESC

(2) Each item starts with "»" or "--", where "»" means the position of the current cursor. Press the DOWN key to move down the cursor position. The item ended with "»" indicates that the item has other contents to be displayed, press Enter to enter the corresponding page.

(3) Press the ESC key to return to the previous class directory; at any position, press the menu key to return to the main menu page.

(4) In the state of dormant, press any button to activate the display screen.

RS485 / CAN Interface

RS485 / CAN communication interface: (RJ 45 port) communicate according to RS 485 / CAN protocol.

RS485- -8P8C vertical RJ 45 socket		CAN- -8P8C vertical RJ 45 socket	
RJ45 pin	Definition	RJ45 pin	Definition
9、 16	RS485-B1	1、 2、 3、 6、 8	NC
10、 15	RS485-A 1	4	CANH
11、 14	GND	5	CAN L
12、 13	NC	7	GND

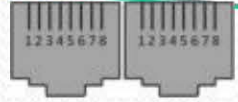

RS 485 / CAN Interface Definition

RS 232 Interface

RS 232 Communication interface: (RJ 11 port) communicate according to RS 232 protocol and the battery output information can be checked.

RS 232- -Use the 8P8C vertical RJ 45 socket	
The RJ 11 pin	Definition
2	NC
3	send data
4	Accept the data
5	GND



RS 232 Interface Definition

RS 485 Interface

RS 485 Communication interface: (RJ 45 port) to communicate according to the RS 485 protocol, read the battery information, and can also be used for multiple sets of lithium battery for parallel communication.

RS485- -8P8C vertical RJ 45 socket		RS485- -8P8C vertical RJ 45 socket	
RJ45 pin	Definition	RJ45 pin	Definition
1、 8	RS485-B1	9、 16	RS485-B1
2、 7	RS485-A 1	10、 15	RS485-A 1
3、 6	GND	11、 14	GND
4、 5	NC	12、 13	NC

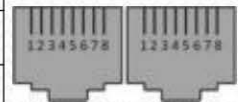

RS 485 Integrated Communication Interface Definition

Power on/off

Power switch: Turn on / off the entire battery pack.

Negative Terminal/Positive Terminal

Power terminal: use the cold terminal RNB 22-8, two pairs of terminals with the same function, one connected to the battery module and the other in parallel to the other battery modules for capacity expansion. For each battery module, each terminal can perform the charging and discharge functions.

Reset

When the BMS is in sleep status, press the button (3~6s) then release, the BMS will be activated, and the LED indicator will be continuously lit from "RUN" for 0.5 seconds.

When the BMS is active, press the button (3~6s) then release, the BMS will sleep and the LED indicator will light from the lowest battery power light for 0.5 seconds.

When the BMS is active, press the button (6~10s) and release, BMS will reset, and all the LED lights are on at the same time for 1.5 seconds.

Dip Switch Address

When multiple battery modules are connected in parallel, each battery module will have a different address code, up to 15 addresses.

Note: In the following table, address 1 is the master, and the other addresses are the slave.

address	Dip Switch Address			
	1#	2#	3#	4#
1	on	off	off	off
2	off	on	off	off
3	on	on	off	off
4	off	off	on	off
5	on	off	on	off
6	off	on	on	off
7	on	on	on	off
8	off	off	off	on
9	on	off	off	on
10	off	on	off	on
11	on	on	off	on
12	off	off	on	on
13	on	off	on	on
14	off	on	on	on
15	on	on	on	on

Dry Contact

dry contact 1-PIN1 to PIN2: often open, low power closed.

Dry contact point 2-PIN3 to PIN4: normally open, closed during fault and protection.

4.2 LED Indicator

STATUS	Normal Alarm Protection	ON/OFF	RUN	ALM	POWER INDICATOR LED						DESCRIPTION						
		●	●	●	●	●	●	●	●	●							
TURN OFF	Sleep	OFF	OFF	OFF	OFF	OFF	OFF	OFF	OFF	OFF	OFF	ALL OFF					
STANDBY	Normal	ON	FLASH1	OFF	According to battery power						STANDYBY						
	Alarm	ON	FLASH1	FLASH3							Low voltage						
CHARGE	Normal	ON	ON	OFF	According to battery power						Max power LED flashing (flash twice, others are on)						
	Alarm	ON	ON	FLASH3							Max power LED flashing (flash twice). When overcharging alarm, ALM does not flash						
	Overcharge protection	ON	ON	OFF							ON	ON	ON	ON	ON	ON	No Charging
	Temperature, over-current protection	ON	ON	OFF							OFF	OFF	OFF	OFF	OFF	OFF	No Charging
DISCHARGE	Normal	ON	FLASH3	OFF	According to battery power												

	Alarm	ON	FLASH3	FLASH3							
	Low voltage protection	ON	OFF	OFF	OFF	OFF	OFF	OFF	OFF	OFF	No Discharging
	Temperature, over-current, short-circuit protection	ON	OFF	ON	OFF	OFF	OFF	OFF	OFF	OFF	No Discharging
FAILURE		OFF	OFF	ON	OFF	OFF	OFF	OFF	OFF	OFF	No Charging/Discharging

4.3 BMS SOC Display

State	Charge						Discharge					
SOC state	L6●	L5●	L4●	L3●	L2●	L1●	L6●	L5●	L4●	L3●	L2●	L1●
0-16.6%	off	off	off	off	off	flash 2	off	off	off	off	off	on
16.6-33.2%	off	off	off	off	flash 2	on	off	off	off	off	on	on
33.2-49.8%	off	off	off	flash 2	on	on	off	off	off	on	on	on
49.8-66.4%	off	off	flash 2	on	on	on	off	off	on	on	on	on
66.4-83%	off	flash 2	on	on	on	on	off	on	on	on	on	on
83-100%	flash 2	on	on	on	on	on	on	on	on	on	on	on
status indicator	on						flash 3					

4.4 LED Flash indication

Flash	lighting hours	stop time
flash 1	0.25s	3.75s
flash 2	0.5s	0.5s
flash 3	0.5s	1.5s

4.5 BMS Function

Protection and alarm	Management and monitoring
Charge / discharge to end	Battery balance
Charge over voltage	Intelligent charging mode
Charge / discharge over-current	Charging current limit
High / low temperature	Calculation of capacity retention
Short circuit	Administrator monitoring
Power cable reverse-connection	operation note

5. Battery Module Safety Processing Guide

5.1 System topology

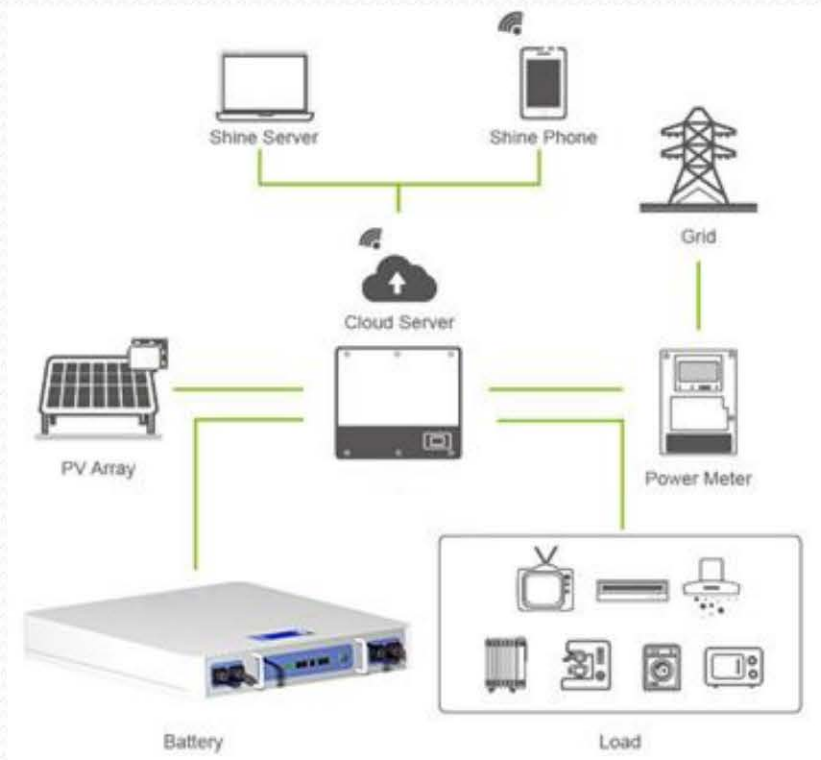

5.2 Label

Lithium Battery Module		⚠ DANGER HIGH VOLTAGE INSIDE	
Model:	YNBB16S100KX-L		<p>*Do not disconnect, disassemble or repair by yourself.</p> <p>*Do not drop, deform, impact, cut or spearing with a sharp object.</p> <p>*Do not place near open flame or incinerate.</p> <p>*Do not sit or put heavy things on battery.</p> <p>*Keep away from moisture or liquid.</p> <p>*Keep out of reach of children, animals or insects.</p> <p>Emergency Situations</p> <p>*If leaking, fire, wet or damaged, switch off the breaker and go away from the battery.</p> <p>*Do not touch the leaking liquid. Do not use water. Sand or dry power extinguisher is usable.</p>
Nominal Voltage:	51.2V		
Charge Voltage:	57.6V		
Cut Off Voltage:	44.8V		
Nominal Capacity:	100Ah/5.12KWh		

5.3 Tool

To install the battery pack, the following tools may be required:



Phillips screwdriver

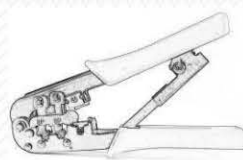

Cable pressurizer



voltmeter

Note: Use appropriate insulation tools to prevent accidental electric shock or short circuit. If not available, cover the entire exposed metal surface of the available tool with insulating tape, except for the tips.

5.4 Safety wearing

It is recommended to wear the following safety equipment when handling the battery module.



insulating gloves



eye protector



safety shoe

5.5 Accessories

Item	Specifications	Quantity
Expansion screw	M8*60mm	6
Connector screw	M8*10mm	4
Ground wire screw	M5*10mm	2
Buckle pendant	N/A	2
Pan-head Screw	M6*20mm	4
Wall-mounted frame	273.6*600mm	1
User operation manual	AW5120	1
Packing list	AW5120	1
Warranty card	AW5120	1

6. Installation

6.1 Connection instructions

Note: For safe operation and operation, when installation of the battery, a separate DC overcurrent protector or a disconnected device is required. In some applications, disconnected device may not be required, but overcurrent protector is still required.

Please refer to the typical amps in the table below for the required fuse or circuit breaker.

Ring terminal:

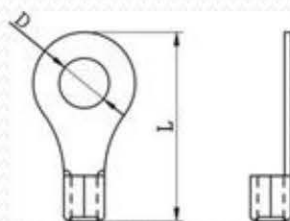

Warning! All wiring work must be done by qualified personnel.

Warning! The use of the appropriate cable to connect the battery is very important for system security and effective operation. To reduce the risk of injury, use the following appropriate recommended cable and terminals.

Recommended battery cable and terminal

battery capacity	Cable size	Ring terminal		
		cable mm ²	size	
			D (mm)	L (mm)
100A h	4AWG	22	8.4	33.5

6.2 Installation conditions

Make sure that the installation location meets the following conditions:

- The area is completely waterproof.
- The floor is flat.
- No flammable and explosive materials.
- The ambient temperature is in the range of 0°C to 50°C.
- Temperature and humidity were maintained at a steady level.
- There is very little dust and dirt in the area.

6.3 Installation instructions

Warning



If the environment temperature exceeds the operating temperature range, the battery module stops working to protect itself. The best operating temperature range for the battery module is 0°C to 50°C. Frequent exposure to harsh temperatures may degrade the performance and life of the battery module.

A . Wall-mounted installation

1. Set 6 points on the wall, use the $\phi 10*90$ shock drill to perform punching operations
2. Put the expansion screws of M8*60 into the drilled hole
3. Place the wall-mounted rack on the M8*60 expansion screw and fix it
4. Combine the buckle pendant on the wall-mounted battery module with the card slot
5. Connect the ground cable of the battery module
6. Connect the communication cable of the battery module
7. Connect the cable to the inverter

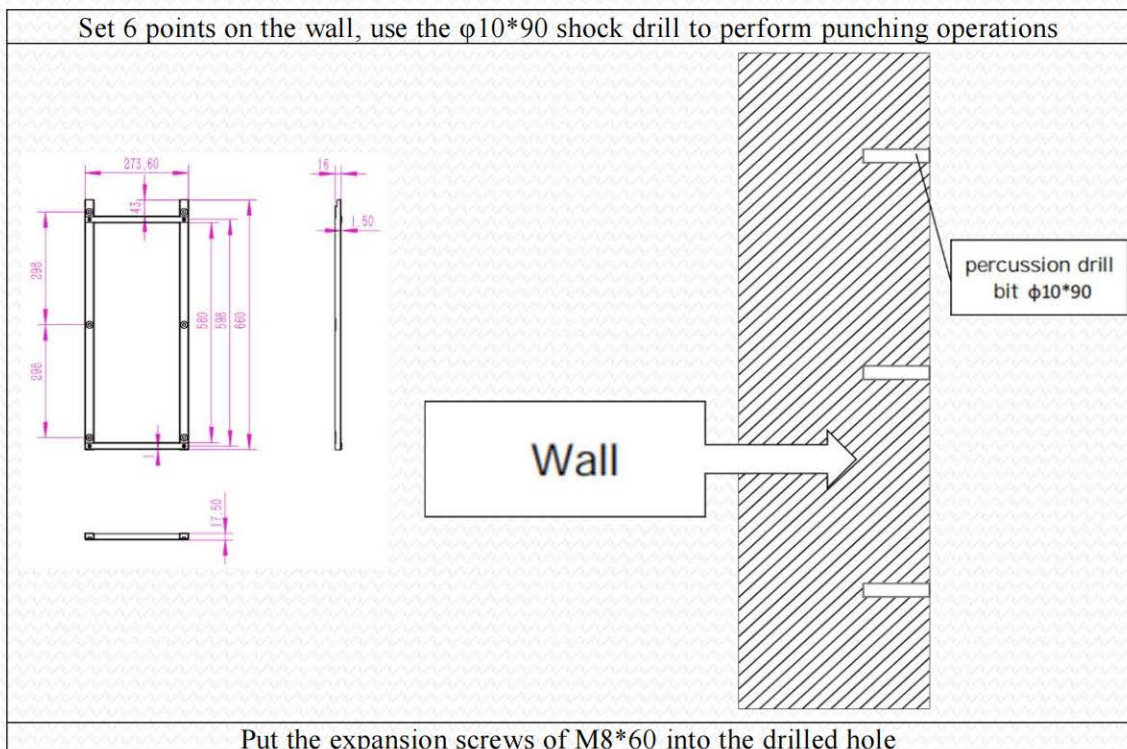

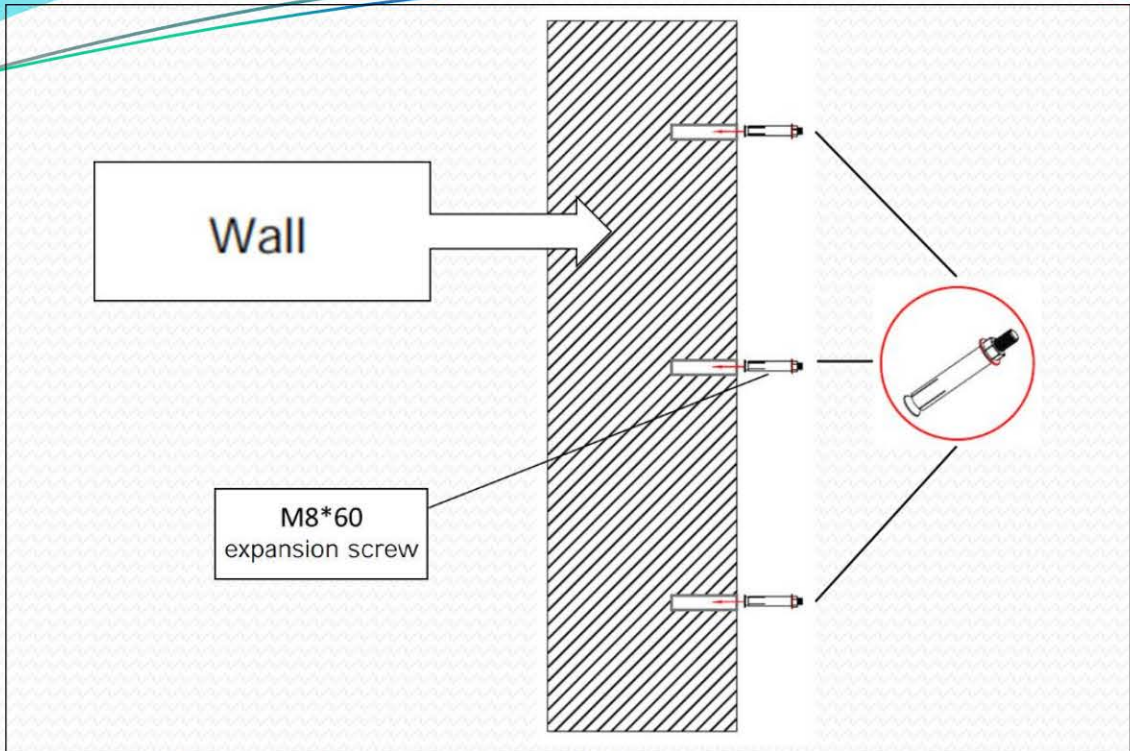

Place the wall-mounted rack on the M8*60 expansion screw and fix it

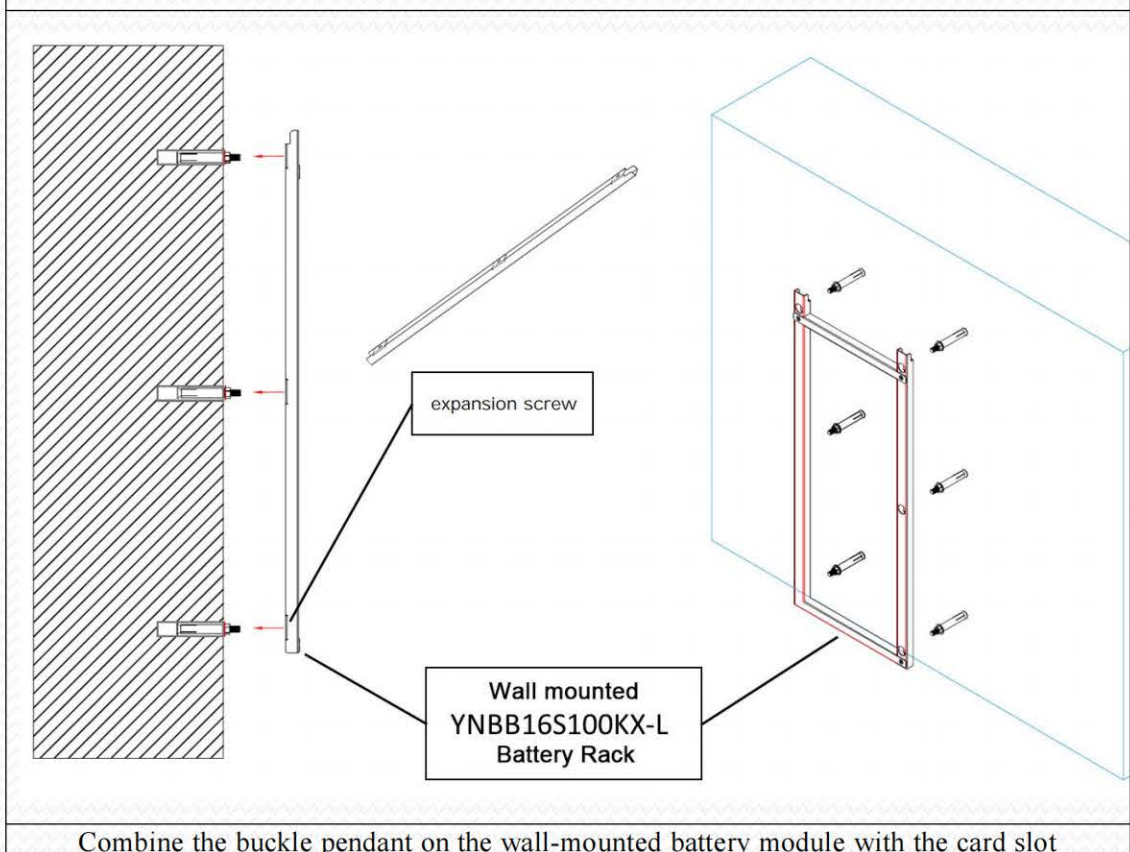

Combine the buckle pendant on the wall-mounted battery module with the card slot

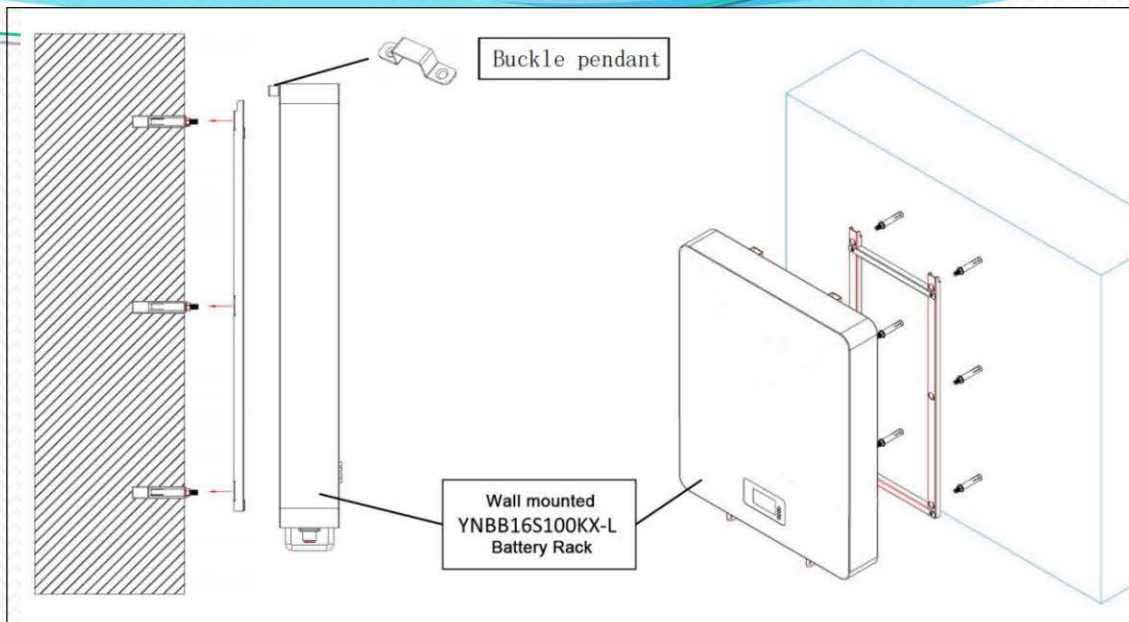

B. Parallel installation

1. Set 6 points on the wall, use the $\phi 10*90$ shock drill to perform punching operations
2. Put the expansion screws of M8*60 into the drilled hole
3. Place the wall-mounted rack on the M8*60 expansion screw and fix it
4. Combine the buckle pendant on the wall-mounted battery module with the card slot
5. Connect the ground cable between the battery modules
6. Connect the communication cable between the battery modules
7. Connect the parallel cables between the battery modules
8. Connect the cable to the inverter

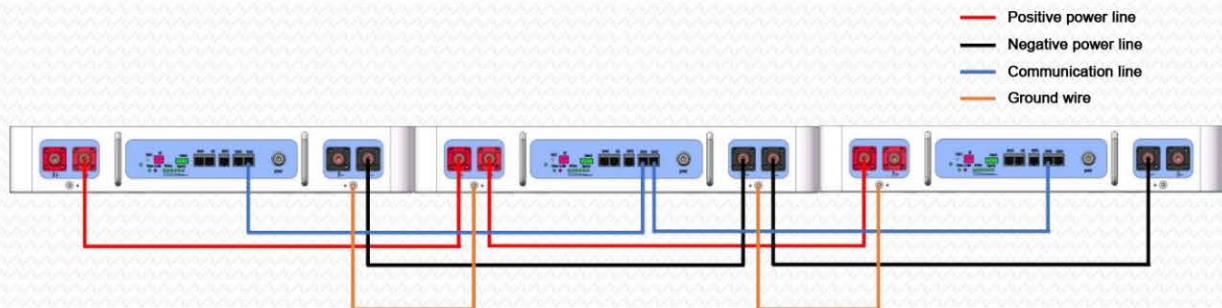

6.4 Boot instructions

6.4.1 Turn on the power supply

Carefully check all the power cables and communication cables.

Turn on all battery modules and the green LED will come on:

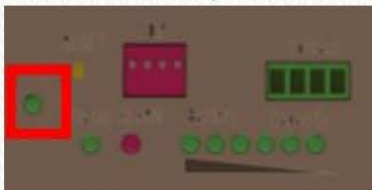

6.4.2 Master and slave mode setting

address	Dip Switch Address			
	1#	2#	3#	4#
1	on	off	off	off
2	off	on	off	off
3	on	on	off	off
4	off	off	on	off
5	on	off	on	off
6	off	on	on	off
7	on	on	on	off
8	off	off	off	on
9	on	off	off	on
10	off	on	off	on
11	on	on	off	on
12	off	off	on	on
13	on	off	on	on
14	off	on	on	on
15	on	on	on	on

Note: Only the master battery module can communicate with the slave battery modules.

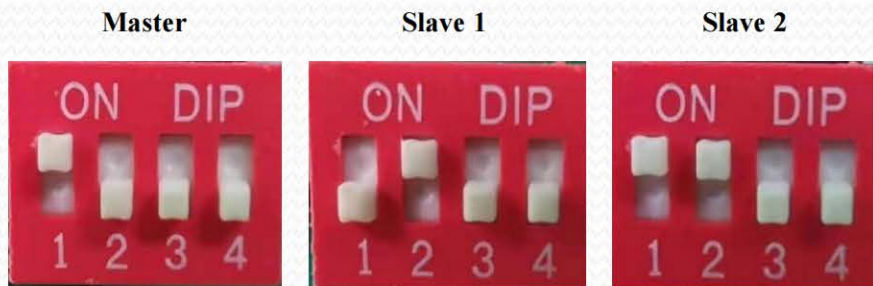

6.4.3 Connection in parallel mode

Normal parallel mode, as shown in the picture

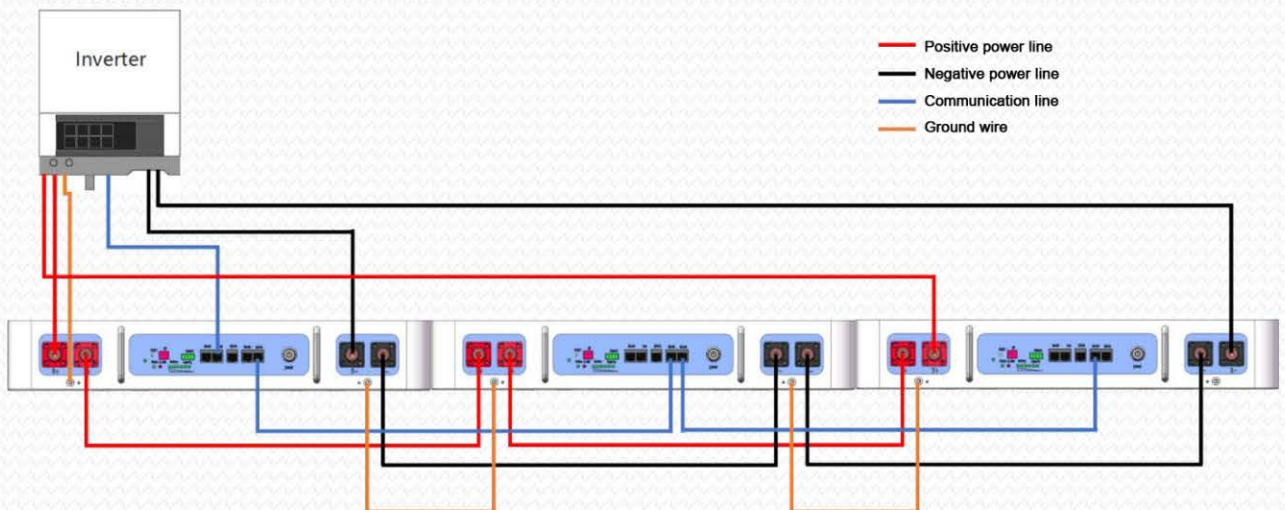

Note: If all the battery LED lights come on and then go off, this means that the battery system is good and works properly.

7. Safety precautions

Warning



7.1 Notes required before installation

7.1.1 After opening the carton, please check the product and packing list first. If the product is damaged or missing parts, please contact the local retailer;

7.1.2 Before installation, you must cut off the power supply, and ensure that the battery is turned off;

7.1.3 The wiring must be correct, do not mistake the positive and negative electrode cable, and ensure no short circuit with external equipment;

7.1.4 Direct connection between the battery and the AC current is prohibited;

7.1.5 The embedded BMS in the battery is designed for 48VDC, please do not connect the battery in series;

7.1.6 The battery system must have a good grounding, and its resistance must be less than 1 Ω ;

7.1.7 Please ensure that the electrical parameters of the battery system are compatible with the relevant equipment;

7.1.8 Keep the battery away from the water and the fire.

7.2 Notes in the operation process

7.2.1 If the battery system needs to be moved or repaired, the power supply must be cut off and the battery must be completely turned off;

7.2.2 It is strictly prohibited to connect the battery with different types of batteries.

7.2.3 It is strictly prohibited to work the battery with the problematic or incompatible frequency converter;

7.2.4 Never remove the battery (the QC label is removed or damaged);

7.2.5 In case of fire, only the dry powder fire extinguisher can be used, and the liquid fire extinguisher is prohibited;

7.2.6 Do not open, repair or remove the battery except those authorized by the manufacturer or distributor. We do not bear any consequences or related liabilities arising from the violation of safe operation or the violation of design, production and equipment safety standards.

REMINDING



- 1) Please read the user manual carefully;
- 2) If the battery is stored for a long time, it needs to be charged once every six months, and the SOC should not be less than 80%;
- 3) After the battery is fully discharged, it should be charged within 12 hours;
- 4) Do not expose the cable to the outside;

- 5) All battery terminals must be disconnected for maintenance;
- 6) If any abnormal, please contact the supplier within 24 hours.
- 7) The direct or indirect losses caused by the above items shall not be covered by the warranty.

8. Abnormal Conditions and Fault Handling

8.1 Troubleshooting steps

- 8.1.1 Check whether the battery can be turned on;
- 8.1.2 If the battery is on, check whether the red light is off, flashing or on;
- 8.1.3 If the red light is off, check if the battery can be charged / discharged.

8.2 Failure recognition

8.2.1 The battery cannot be turned on, and the lights are not on or flashing after the boot.
If the external power of the battery is on, the state light is flashing, the external power supply voltage is above 48V, and the battery still cannot be turned on, please contact the supplier.

8.2.2 The battery can be turned on, but the red light is on and cannot be charged or discharged.

The red light is on, which means the system is not normal, check the following values:

Temperature: over 56°C or below-20°C, the battery does not work.

Solution: Move the battery to the normal operating temperature range of-10°C to 50°C.

Current: If the current is greater than 100A, the battery protection is turned on.

Solution: check whether the current is too large, if it is too large, to change the setting of the power side.

High voltage: If the charging voltage exceeds 57.6V, the battery protection will be turned on.

Solution: Check whether the voltage is too high, and if so, change the setting of the power supply side.

Low voltage: When the battery discharges to 44.8V or lower, the battery protection is turned on.

Solution: Charge the battery for a while, and the red light will go out.

Excluding the above four points, if the fault still cannot be found, please turn off the battery and repair it.

8.3 Charging troubleshooting

8.3.1 Unable to charge:

Disconnect the power cable and measure the voltage on the power side. If the voltage is 53~54V, restart the battery, connect the power cable and try again. If still not, turn off the battery and contact the dealer.

8.3.2 Failure to discharge:

Disconnect the power cable and measure the voltage on the battery side. If the voltage is lower than 48V, please charge the battery. If the voltage is above 48V, and still cannot discharge, please turn off the battery and contact the dealer.

9. Emergency

9.1 Battery leakage

If the battery has leaked the electrolyte, avoid contact with the leaked liquid or gas. If exposed with this substances, the following measures should be taken immediately:

Inhalation: evacuate the contaminated area and seek medical care.

Eye contact: rinse the eyes with running water for 15 minutes and seek medical care.

Contact with the skin: wash the affected area thoroughly with soap and water, and seek medical treatment.

Intake: induced vomiting and seek medical assistance.

9.2 Fire

Don't use water! Only dry powder extinguishers; if possible, move the battery pack to a safe area before catching fire.

9.3 Water

If the battery pack is wet or soaked in water, do not contact it, and then contact the manufacturer or authorized dealer for technical support.

9.4 Battery damage

Damaged batteries are dangerous and must be dealt with in the most prudent manner. They are not suitable for use and may pose a danger to persons or property. If the battery pack appears to be damaged, pack it in the original container and return it to the manufacturer or authorized distributor.